

Manual | Form Wash

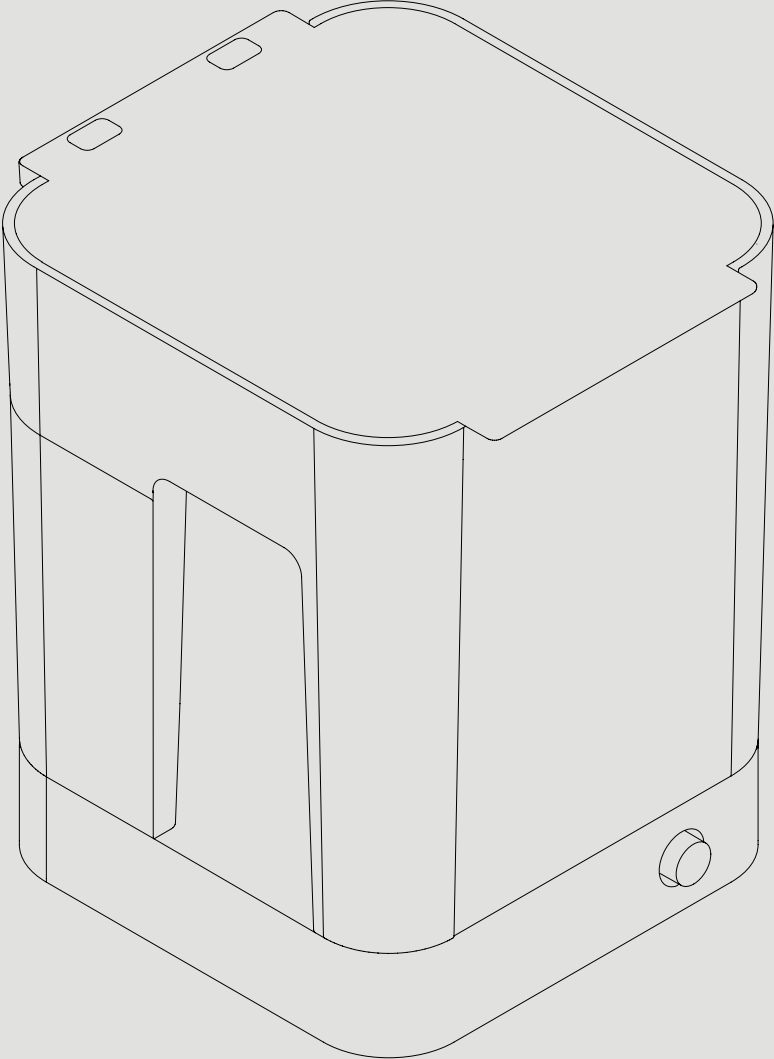

Installation and Usage Instructions

Form Wash

Desktop Stereolithography Print Cleaner

Original English instructions and translations

Please read this manual carefully and keep it for future reference.

November 2019

REV 01

© Formlabs

formlabs 

Table of Contents

1.	Preface	8
1.1	Read and Retain Instructions	8
1.2	Obtaining Documentation and Information	8
2.	Introduction	10
2.1	Intended Use	10
2.2	Product Elements	11
2.3	Technical Data	12
2.4	Form Wash Controls	12
3.	Safety Warnings	13
3.1	Component and Subsystem Safety	13
3.2	Personal Protective Equipment (PPE)	15
3.3	Specifications of Tools to be Used	15
4.	Preparation and Set Up	16
4.1	Arranging the Workspace	16
4.2	Unboxing the Form Wash	16
4.3	Installing the Form Wash	16
4.4	Transporting the Form Wash	18
5.	Using the Form Wash	20
5.1	Operational Environment	20
5.2	Washing	20
5.3	Considerations for Specific Geometries	22
5.4	Device Management	23
5.5	Emergency and Exceptional Situations	25
6.	Maintenance	26
6.1	Inspecting the Product	26
6.2	Inspection Tasks Between Wash Cycles	26
6.3	Monthly Inspection and Maintenance Tasks	27
6.4	Periodic Inspection and Maintenance Tasks	27
6.5	Planned Maintenance Procedures	27

7.	Troubleshooting and Repair	30
7.1	Restarting with a Power Cycle	30
7.2	Troubleshooting	30
7.3	Disassembly and Repair	30
8.	Disposal	32
8.1	Guidance for Recycling and Disposal	32
9.	Index	33
10.	Glossary	34



Read and understand this manual and its safety instructions before using the Form Wash. Failure to do so can result in serious injury or death.

DISCLAIMER

Formlabs has made every effort to ensure these instructions are as clear, complete, and correct as possible. The information provided in this documentation contains general descriptions and/or technical characteristics of the performance of the products contained herein. This documentation is not intended as a substitute for, and is not to be used for, determining suitability or reliability of these products for specific user applications. It is the duty of any such user or integrator to perform the appropriate and complete risk analysis, evaluation, and testing of the products with respect to the relevant specific application or use thereof. Neither Formlabs nor any of its affiliates or subsidiaries shall be responsible or liable for misuse of the information that is contained herein. If you have any suggestions for improvements or amendments or have found errors in this publication, please notify us.

Copyright © 2019 by Formlabs. All rights reserved.

support.formlabs.com

TRADEMARKS

All product names, logos, and brands are property of their respective owners. All company, product, and service names used in this manual are for identification purposes only. Use of these names, logos, or brands does not imply endorsement.

DOCUMENT REVISIONS

Date	Version	Document Changes
Oct 2015	REV 00	Initial publication of Quick Start Guide and Safety pamphlet
Nov 2019	REV 01	Initial publication

1. Preface

Congratulations on purchasing the Form Wash. On behalf of the employees who create and support Formlabs technology, we thank you for your purchase.

The instructions in this manual provide information for skilled persons to understand safety, setup and installation, operation, and maintenance of the Form Wash. These instructions are intended for anyone who is installing, operating, maintaining, or otherwise interacting with the Form Wash. Supervise young or inexperienced users to ensure an enjoyable and safe operation.

1.1 Read and Retain Instructions

Read and understand this manual and its safety instructions before using the Form Wash. Failure to do so can result in serious injury or death. Keep all safety information and instructions for future reference and provide them to subsequent users of the product.

Follow all the instructions. This will avoid fire, explosions, electric shocks, or other hazards that may result in damage to property and/or severe or fatal injuries.

The Form Wash shall only be used by persons who have fully read and understood the contents of this usage manual. Ensure that each person who uses the Form Wash has read these warnings and instructions and follows them. Formlabs is not liable for cases of material damage or personal injury caused by incorrect handling or non-compliance with the safety instructions. In such cases, the warranty will be voided.

1.2 Obtaining Documentation and Information

Visit support.formlabs.com to:

- Access the latest version of all Formlabs product documentation.
- Contact Formlabs to request documentation, usage instructions, and technical information.
- Submit any comments or feedback regarding what is good and what can be improved.
- Request additional training.

1.2.1 Support and service

Retain a record of the original purchase to request warranty services. Service options depend on the status of the specific product's warranty. Include the serial name of the product when contacting Formlabs for product support.

Instead of a serial number, all Formlabs machines have a serial name, which is a unique identifier to track the history of manufacturing, sales, and repair, as well as to distinguish usage when connected to a network. The serial name is on the back panel of the machine in this format: "AdjectiveAnimal."

Service providers of Formlabs products also provide support and service. To the extent that Formlabs or a certified service provider offers other or extended warranties, the terms of the separate offer may apply. For products purchased from certified service providers, contact the original service provider for assistance before contacting Formlabs.

For any support or service requests, including product information, technical assistance, or assistance with instructions, contact Formlabs Services or a certified service provider:

support.formlabs.com

USA

Formlabs, Inc.
35 Medford St.
Somerville, MA, USA, 02143

Germany

Formlabs GmbH
Nalepastrasse 18-50
12459 Berlin, Germany

1.2.2 **Returns**

Formlabs accepts returns for unopened, unused, and undamaged products within 30 days of the shipment date. Returns must be authorized by Formlabs. Visit [Formlabs.com](https://www.formlabs.com) for more detailed information about returning your purchase.

1.2.3 **Warranty**

This product is protected under warranty. Formlabs offers a warranty for all Formlabs-branded hardware. Unless otherwise expressly stated, the Terms of Service, including the Warranty, constitute the entire agreement between you and Formlabs with respect to the Service and any product you purchase from Formlabs and supersedes all prior or contemporaneous communications, proposals and agreements, whether electronic, oral or written, between you and Formlabs. Read the warranty for more details on the Formlabs warranty for your region:

US [formlabs.com/support/terms-of-service/#Warranty](https://www.formlabs.com/support/terms-of-service/#Warranty)

EU (EN) [formlabs.com/support/terms-of-service/eu/](https://www.formlabs.com/support/terms-of-service/eu/)

EU (DE) [formlabs.com/de/support/terms-of-service/eu/](https://www.formlabs.com/de/support/terms-of-service/eu/)

EU (FR) [formlabs.com/fr/support/terms-of-service/eu/](https://www.formlabs.com/fr/support/terms-of-service/eu/)

2. Introduction

2.1 Intended Use

The Form Wash automatically cleans uncured liquid resin from 3D printed parts' surfaces. The final performance characteristics of cured photopolymer resin may vary according to your compliance with the instructions for use, application, operating conditions, material combined with, end use, or other factors.



NOTICE

In some cases, the additive manufacturing process may inherently result in variable performance characteristics between manufacturing runs or within a specific part. Such variances may not be apparent and may result in unexpected defects in additively fabricated parts.



WARNING

You must independently verify the suitability of additive manufacturing, stereolithography, Form Wash, and any specific designs or materials employed for the application and intended purpose before use. In no event shall Formlabs be liable for any loss, death, or bodily injury that you suffer, or that you cause to any third party, in connection with your use of Formlabs products. To the fullest extent legally permitted Formlabs EXPRESSLY DISCLAIMS ANY IMPLIED OR EXPLICIT WARRANTY OF FITNESS for a particular usage, the particular nature and circumstances of said usage being unforeseen and unforeseeable to Formlabs.



WARNING

Formlabs is not a manufacturer of medical devices. Formlabs provides tools and materials that may be used in many applications, but makes no claims as to the safety or effectiveness of any specific devices made using Formlabs products. Certain Formlabs products, such as those commonly known in the industry as “biocompatible” resins, have been engineered to comply with relevant industry standards. The specific standards and most relevant technical specifications may be identified within the technical data sheets and have been tested according to relevant testing protocols for those standards and specifications. Biocompatible resins are a speciality product, developed for use by medical professionals, and should be used in accordance with their instructions for use.



WARNING

Do not modify. The Form Wash is intended for use as-is. Modifying the unit without explicit approval and directions from Formlabs will invalidate your warranty, and could potentially ruin the machine and cause you bodily harm. Never remove the bottom panel of the unit.

2.2 Product Elements

- 1 **Platform Mount** Holds the build platform when washing parts on the platform.
- 2 **Basket** Removable container holds parts to wash without the build platform.
- 3 **Basket Mount** A single hook secures the basket to raise and lower.
- 4 **Outer Lid** Limits solvent evaporation. Keep the lid closed when not in use.
- 5 **Inner Lid** A hinged, secondary lid opens and closes to contain solvent while allowing parts to be lowered or raised from the bucket.
- 6 **Wash Bucket** Removable container holds a maximum of 8.6 L of solvent. A rotating impeller at the bottom circulates the solvent.
- 7 **Display** Shows status, time, and options for configuring the Form Wash.
- 8 **Knob** Turn or press to adjust time and to start, pause, or end a wash cycle.
- 9 **Tool Storage** Each side has designated locations for storing each tool.
- 10 **Power Supply** Provides power to the Form Wash. Specifications: 24 V, 2 A.
- 11 **Solvent** Not included. Dissolves liquid resin from printed parts' surfaces.

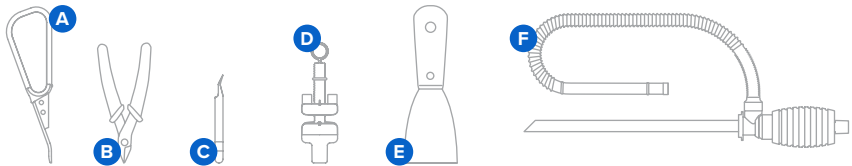
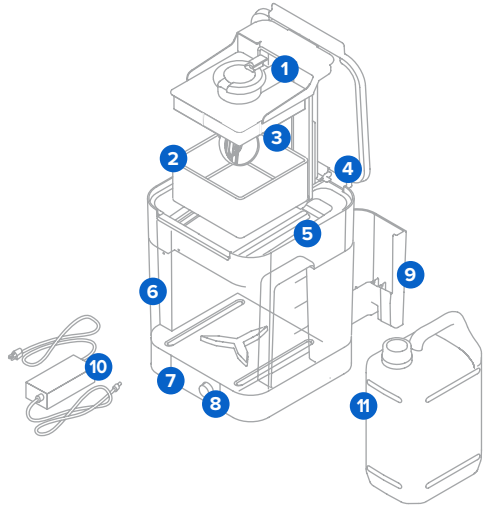

The Form Wash includes storage space for commonly used tools during the print cleaning process.

- A **Flush Cutters** Use to carefully remove support tips from printed parts.
- B **Removal Tool** Apply pressure under the base generated by PreForm to release the base of your parts from the build platform.
- C **Tweezers** Use to handle small parts or to manipulate supports after printing.
- D **Hydrometer** If using isopropyl alcohol (IPA) as a solvent (or another solvent with an equivalent specific gravity), float in IPA to measure the IPA's resin concentration (based on previous calibration in fresh IPA). Other solvents may require a different hydrometer for a different specific gravity range.
- E **Scraper** Can be used to remove parts from the build platform, as well as to carefully clean and inspect the resin tank for cured material.
- F **Siphon Pump** Transfer solvent between the wash bucket and a solvent storage container. See **10 Glossary** for full product terminology.

2.3 Technical Data

Shipping Weight	9.0 kg (20 lb)
Product Weight	6.7 kg (14.5 lb)
Shipping Dimensions	33.0 × 35.4 × 45.6 cm (14 × 14 × 18 in)
Product Dimensions	26.2 × 29.3 × 34.0 cm (10.3 × 11.5 × 13.4 in) Height when open: 64 cm (25.2 in)
Minimum Space Requirement	38.9 × 41.9 × 64.0 cm (15.3 × 16.5 × 25.4 in)
Power Requirements	100–240 V 2.0 A 50/60 Hz 50 W
Electrical Safety Standard	60950-1:2005+A1:2009+A2:2013 (and applicable national deviations)
Sound Emission	Does not exceed 70 dB(A).
Bucket Volume	8.6 L
Maximum Part Size	14.5 × 14.5 × 17.5 cm (5.7 × 5.7 × 6.9 in)
Operating Temperature	Suggested 18–28 °C (64–82 °F)
Agitation Method	Magnetically coupled impeller

2.4 Form Wash Controls

When connected to power, use the knob to program and operate the Form Wash:

- Rotate the knob counterclockwise or clockwise to move between items in the menu.
- Press the knob to select an option on the display.

The following options are available from the main menu on the Form Wash display:

- **Start:** Lowers the mount and basket and initiates the washing process.
- **Open:** Raises the mount and basket.
- **Sleep:** Lowers the mount and basket. The wash cycle does not start until **Start** is selected.
- **Time:** Press the knob to select and adjust the time, indicated in minutes. Check each material's recommended wash time before beginning a cycle.

After beginning a wash cycle, the display shows the remaining time and additional menu options:

- **Pause:** Stop the agitation and lift the platform and basket mount, while maintaining the remaining time in the wash cycle.
- **End:** Cancel the remaining time in the wash cycle while also stopping the agitation and lifting the platform and basket mount.

3. Safety Warnings



Read and understand this manual and its safety instructions before using the Form 3. Failure to do so can result in serious injury or death.

Supervise young or inexperienced users to ensure enjoyable and safe operation. The instructions contain warnings and safety information, as explained below:



Danger indicates a hazard with a high level of risk which, if not avoided, will result in death or serious injury.



Warning indicates a hazard with a medium level of risk which, if not avoided, could result in death or serious injury.



Caution indicates a hazard with a low level of risk which, if not avoided, could result in minor or moderate injury.



Notice indicates information considered important, but not hazard-related.



DANGER: Isopropyl alcohol is a flammable chemical.

3.1 Component and Subsystem Safety

3.1.1 Electronic Components

The Form Wash is a professional appliance that includes electronic components. As with any such appliance:



- Do not operate the Form Wash with a damaged cord or plug.
- Always disconnect power before cleaning.
- Only use well-maintained equipment.
- Operate on a clear and level surface.

3.1.2 Sharp Tools

The accessories include sharp tools such as: a part removal tool, flush cutters, a scraper, and tweezers.



Cutting hazard. Using these tools on slippery surfaces (such as a resin-coated build platform) can result in sudden movement. Orient sharp tools away from yourself, especially when cutting or scraping.

3.1.3 Resin

Respect Formlabs resin like any household chemical. Follow standard chemical safety procedures and Formlabs resin handling instructions.



Wear gloves whenever handling liquid resin or solvents. If swallowed, immediately call a poison center or medical professional.

In general, Formlabs resin is not approved for use with food, drink, or medical applications on the human body. However, biocompatible resins, such as Dental SG, are biologically safe for specific types and lengths of exposure to the human body. Refer to information about each specific resin for more detail.



Never ingest resin in liquid or solid form.



Always consult the SDS (Safety Data Sheet) as the primary source of information to understand safety and handling of Formlabs materials. Combinations of resin and solvent should be handled according to the restrictions of both. For questions, consult the appropriate SDS(s).

3.1.4 Radio Interference

This equipment has been tested and found to comply with the limits for a Class B digital device, pursuant to CFR Title 47, Part 15 of FCC Rules. These limits are designed to provide reasonable protection against harmful interference when the equipment is operated in a commercial environment. This equipment generates, uses, and can radiate radio frequency energy and, if not installed and used in accordance with the instruction manual, may cause harmful interference to radio communications. Operation of this equipment in a residential area is likely to cause harmful interference in which case the user will be required to correct the interference at their own expense.

Changes or modifications to this product not authorized by Formlabs could void the electromagnetic compatibility (EMC) and negate your authority to operate the product.



Use of controls or adjustments or performance of procedures other than those specified herein may result in hazardous radiation exposure.

3.1.5 Solvents



Formlabs does not manufacture solvents. Always consult the safety data sheet (SDS) from your solvent supplier as the primary source of information for storage and handling.

Comply with local or organizational regulations, which may have specific requirements for: storage, ventilation, personal protective equipment, and disposal of solvents.

Some solvents, such as isopropyl alcohol (IPA) are flammable and should be stored away from sources of ignition. Handle solvents with gloves in a well-ventilated area. Keep storage container lid(s) closed whenever possible. More information is available at support.formlabs.com. Always refer to the supplier's SDS.

Use the included siphon pump to avoid overfilling or spilling solvent. Operate the Form Wash on a clear and level surface. Always remove the wash bucket or empty alcohol from the wash bucket before storing or transporting the Form Wash.

3.2 Personal Protective Equipment (PPE)



Resin and solvents may cause skin irritation or an allergic skin reaction. Wear gloves when handling liquid resin, liquid solvent, or resin-coated surfaces. Wash skin with plenty of soap and water.



Some methods of support removal may cause small pieces of supports to break away. Beware of flying debris. Wear eye protection and gloves to protect the skin and eyes.

3.3 Specifications of Tools to be Used

The Form Wash shall only be used with supplied accessories and additional tools recommended by Formlabs. Third-party accessories and materials may cause damage.

Purchase additional supplies:

- **Paper towels.** Keep paper towels in stock to ensure a clean work environment for printing and finishing.
- **Solvent.** Multiple solvents are suitable for washing SLA printed parts. Choose the solvent that best meets your needs and fits your workflow. For more information about solvents and a complete list of compatible solvents, visit support.formlabs.com.
- **Personal Protective Equipment.** Powder-free, chemical-resistant, disposable gloves (nitrile or neoprene)

4. Preparation and Set Up



Consider the weight and dimension of the product for installation.

For the fastest unboxing and setup experience, purchase 10 liters of your selected solvent in advance and review the Form Wash system overview before starting.

4.1 Arranging the Workspace

For best results:

1. Choose a stable, level workspace to install and operate the Form Wash.
2. Reserve the following minimum dimensions for the most convenient access:
 - Width: 38.9 cm (15.3 in)
 - Depth: 41.9 cm (16.5 in)
 - Height: 64 cm (25.2 in)
3. Allow additional space for accessories, such as the Formlabs SLA printer, Finish Kit, and Form Cure.
4. Ensure either the wall outlet or power supply for the Form Wash is easily accessible. To disconnect the equipment from mains electricity and power off the unit, unplug the power cable from the wall outlet, or the power supply.

4.2 Unboxing the Form Wash

The Form Wash ships in a cardboard carton, protected by foam inserts above and below the machine. The upper foam insert also contains the accessories. During unboxing, inspect the Form Wash for any damage or missing items. In the case of damage or missing items, contact Formlabs or the certified service provider.

To unbox the Form Wash:

1. Open the box from the top.
2. Lift and remove the foam insert containing the accessories.
3. Use the provided handles on each side of the unit to lift the Form Wash out of the box.
4. Remove internal packaging.
5. Raise the mount to access and remove any twist ties that secure the bottom of the basket to the basket mount.
6. Remove the siphon pump from the wash bucket.



Remove all packaging material before connecting power. Retain all packaging and inserts for warranty service.

4.3 Installing the Form Wash

To prepare to use the Form Wash, follow the steps below to fill the wash bucket with solvent. If you are using isopropyl alcohol, calibrate the included hydrometer. The hydrometer can only be calibrated in fresh IPA (or another solvent with an equivalent specific gravity) with a concentration of 90% or higher.

4.3.1 Assemble Siphon Pump

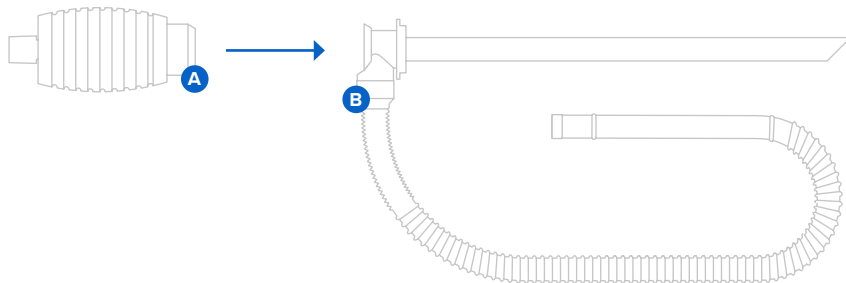

To assemble the siphon pump, screw the handle **A** into the rigid tube **B** of the siphon pump. Use the siphon pump to avoid overfilling or spilling solvent. The siphon pump is designed to transfer liquid without splashing. This includes transferring both used solvent into empty containers as well as fresh solvent into the wash bucket.

4.3.2 Fill Wash Bucket with Solvent

To fill the Form Wash:

1. Open the outer lid.
2. Pour or siphon solvent into the wash bucket to fill to a level between the minimum (7.8 L) and maximum (8.6 L) fill lines. For more information about using the siphon pump, visit support.formlabs.com.

4.3.3 Connect Power Supply

Connect the power cable and external supply to the Form Wash and a power source.



NOTICE

The Form Wash includes a USB port to allow for firmware updates.

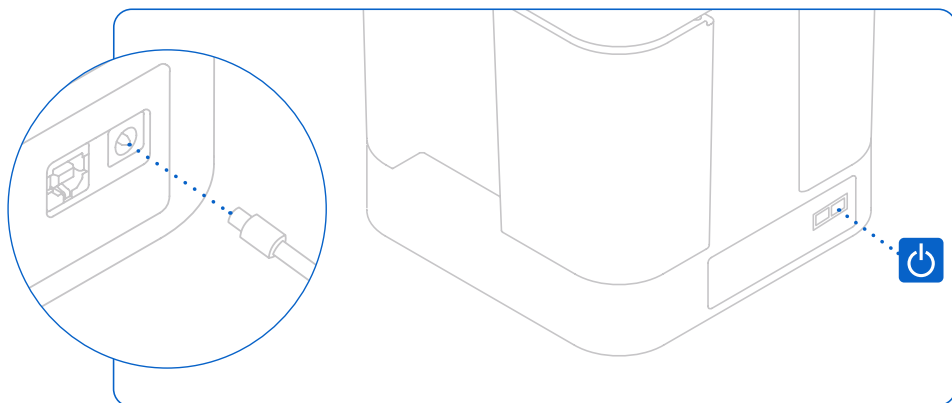

4.3.4 Calibrate the Hydrometer (IPA Only)

If you have filled your Form Wash with IPA (or another solvent with an equivalent specific gravity), calibrate the included hydrometer. Once calibrated, the hydrometer can be used to determine when the solvent should be changed.

To calibrate the hydrometer:

1. Hold the handle **A** and release the tool in the wash bucket's fresh IPA.
2. Slide the O-ring **B** along the ribbed stem until the O-ring aligns with the short wings **C** at the top of the float.
3. Leave the O-ring in this position. The alignment of the wings and O-ring is used to check the resin concentration of IPA between washes.
4. Store the hydrometer in the tool storage area at the back of the unit.

The Form Wash is ready for use once the wash bucket has been filled between the minimum and maximum fill lines and the hydrometer is calibrated. Choose whether to wash the part on the build platform or in the basket.

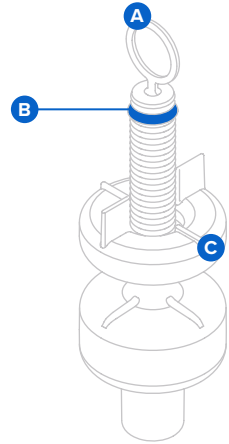

4.4 Transporting the Form Wash

Refer to **2.2 Technical Specifications** for product weight and dimensions. Keep the packaging for transportation or shipping.

The Form Wash complete packaging kit consists of:

- 1 outer cardboard carton
- 1 foam bottom insert
- 1 foam upper insert, which holds the small accessory boxes
- 1 protective plastic bag
- Plastic wrap



NOTICE

Original packaging may be required for warranty service. Do not ship with solvent inside the bucket. Solvent left inside the Form Wash can damage the unit in transit, which may lead to additional fees or void the warranty.

To prepare to transport the Form Wash:

1. Remove solvent.
2. Wipe residual solvent from the wash bucket and inner lid.
3. Remove tools from tool storage.
4. Insert the wash bucket.
5. Insert the wash basket.
6. Lower the basket mount.
7. Close the outer lid.
8. Wrap the unit with plastic wrap to secure the tool storage and lids.

9. Reassemble the box.
10. Place the bottom foam insert in the box.
11. Place the Form Wash on top of the bottom foam insert.
12. Place the upper foam insert on top of the Form Wash.
13. Seal the box with tape.



When shipping a machine to Formlabs for service, do not ship the accessory tools or the power supply. Accessories will not be returned after service. The product's original packaging is required for warranty service. Contact other authorized resellers for unique guidance on shipping requirements.

5. Using the Form Wash

5.1 Operational Environment

Operate the Form Wash in a well-ventilated room with a temperature of 18–28 °C (64–82 °F). For optimal performance, do not exceed this range.

5.2 Washing

5.2.1 Insert Print

To wash a printed part:

1. Use the display and knob to raise the platform and basket mounts.
2. For convenience, install the build platform with printed parts directly in the Form Wash to clean parts before removal **1**. Align the top lip of the build platform with the arms of the Form Wash platform mount, and fully insert to touch the back.

Parts must be washed on the build platform or in the basket. Ensure parts are fully secured to the build platform when washing parts without the basket installed. Washing loose parts directly in the wash bucket—whether intentionally or accidentally—may damage printed parts, create noise, and interfere with solvent agitation.

Parts can also be washed in the basket **2**, either as an alternative or in addition to the platform mount. Place parts directly in the basket after removing them from the build platform using the removal tool, scraper, or flush cutters. The basket comes installed in the Form Wash.

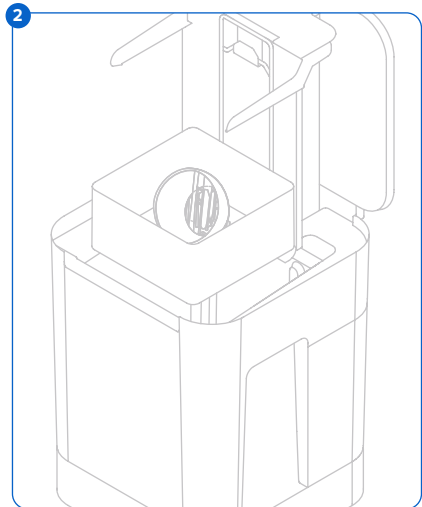
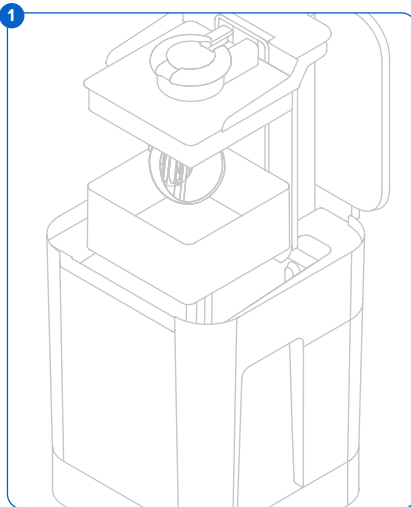

To remove the basket from the Form Wash:

1. Remove the build platform from the platform mount.
2. Lift the basket vertically out of the basket mount.

5.2.2 Set Wash Time

To wash parts for a specific amount of time:

1. Turn the knob to navigate the display menu and adjust the wash time.
2. Press the knob to select or confirm.
3. Once the wash cycle begins, select **Pause** to raise the platform and basket.

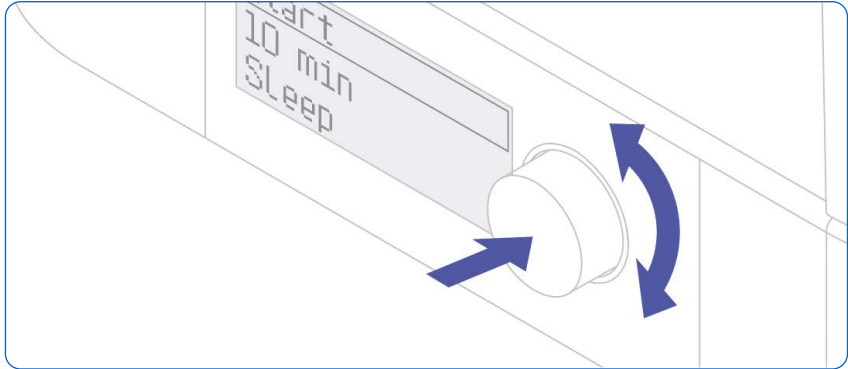

Part washing time depends on the resin and solvent used. Check support.formlabs.com for specific wash time recommendations. Wash for additional time when using partially resin-concentrated solvent. The wash cycle begins when the platform and basket lower. Ensure that the outer lid closes and is not obstructed.

To adjust the wash cycle time:

1. Press the knob to access the display menu.
2. Select **Pause** to raise the platform and basket.

5.2.3 Drain and Dry Prints

The platform mount and basket raise automatically at the end of the wash cycle. Solvent drains into the wash bucket as parts dry and drips onto the inner lid. Thoroughly drain solvent from printed parts; carefully check and drain concave or hollow geometries that may hold additional solvent. Allow parts that have been washed in any solvent that evaporates readily to air dry for at least 30 minutes after washing and draining. Solvents that do not evaporate readily, such as tripropylene monomethyl ether (TPM), should be washed off the parts with a secondary water rinse. Consult support.formlabs.com for additional information about working with specific solvents.

Ensure appropriate ventilation while the solvent evaporates. Observe necessary safety precautions, according to the solvent supplier's SDS. Options for drying include air drying or forced air. Forced air, such as a fan or clean compressed air, may dry parts more quickly.



Check inside cavities and channels for uncured resin or liquid solvent. Remove residual liquid before drying to avoid fully or partially cured resin in unwanted areas. Compressed air may be helpful to empty internal channels before drying.

To begin the next wash immediately, dry the parts outside of the Form Wash. Take extra care with sharp objects and slippery surfaces when removing wet parts from the build platform.

5.2.4 **Collect Prints**

Remove the build platform or parts from basket, depending on the wash method used in **5.2.1**

Insert Print.

5.2.5 **Finish Your Print**

After washing parts on the build platform, remove parts from the build platform with the removal tool, scraper, or flush cutters.

Once each part is washed and dried, check the specific material's post-curing settings on support.formlabs.com. Post-curing is optional for Standard Resins and required for many other materials to achieve their optimal properties.

After post-curing (if necessary), use the flush cutters that come in your Finish Kit to carefully cut the supports attached to the part(s). Supports can also be removed before post-curing, but parts may warp under exposure to light and heat without structural support.



Wear safety glasses to protect eyes from dislodged fragments of supports.

You can sand support marks and polish your parts for a smooth finish.

5.3 **Considerations for Specific Geometries**

Consider the specific geometry of each part when choosing a method to wash the part and the sequence of steps. Take special care when washing parts that are large, hollow, concave or cup shaped, or have internal chambers or channels that hold solvent, air, or uncured resin inside.

5.3.1 **Hollow Geometries**

Design hollow parts with drainage holes for successful printing. During the washing process, the drainage hole allows the solvent to flow inside and clean the internal surfaces. Take care when removing hollow parts from the alcohol bath. Check to ensure that all solvent drains out of the chamber before transferring the part to another surface.

5.3.2 **Internal Channels**

Thin channels, such as those used in micro-fluidic designs, may not drain entirely on their own. Use a syringe filled with clean solvent to flush out internal channels. After cleaning, use compressed air to fully drain and dry the channel.

5.3.3 **Large Parts**

Parts move around the basket with the circulation of alcohol in the wash bucket. Check the path of the basket and inner lid to ensure that all parts can safely raise out of the bucket when the wash cycle completes and the basket raises. Parts that hang outside the basket perimeter may dislodge the inner lid when the wash cycle completes.

Whether using the build platform or basket as a wash method, the maximum single part size that can be washed in the Form Wash is 14.5 × 14.5 × 17.5 cm (5.7 × 5.7 × 6.9 in).

5.3.4 **Concave Surfaces, Printed and Washed on the Build Platform**

Hollowed parts—such as hollowed dental models—printed directly on the build platform can trap resin inside during the wash cycle, when they are washed still attached to the build platform. Consider washing these parts in the Form Wash basket or adding a second wash cycle after removing them from the build platform to remove uncured resin that is not removed when washing on the build platform alone.

5.3.5 **Parts Larger than 1.8 L**

The solvent in the Form Wash can overflow when washing parts that are larger than 1.8 L of enclosed volume. Consider how much solvent a printed part will displace before washing in the Form Wash. Remove some solvent from the wash bucket before washing a large print.

5.4 **Device Management**

5.4.1 **Extending Solvent Lifetime**

The solvent in the Form Wash builds up a higher concentration of resin after each wash, as liquid resin from each wash cycle accumulates over time. As the solvent becomes more resin-concentrated, a layer of diluted resin coats the outermost surface of printed parts after washing. As the solvent dries, a thin layer of liquid resin is left behind on the part's surface, causing the surface to feel tacky. Thus, the part is only as clean as the cleaning solution.

When washing parts on the build platform, scrape excess liquid resin back into the resin tank before placing the build platform in the Form Wash.

To achieve the cleanest parts, replace used solvent with fresh solvent frequently or consider a multi-step washing process. As solvent evaporates, add fresh solvent to keep the fill level between the minimum and maximum lines.

Maintain separate wash buckets for each resin type or similar colors to preserve the best possible surface quality and performance:

- Biocompatible resins - to comply with biocompatibility regulations
- Castable Wax Resin - to avoid color transfer
- Castable Resin - to avoid color transfer
- Rigid Resin - to prevent glass particles adhering to parts printed with other resins
- Ceramic Resin - to prevent ceramic particles adhering to parts printed with other resins

Solvent lifetime depends in part on the chemical properties of the solvent. Visit support.formlabs.com for detailed information about different solvents and solvent performance.

5.4.2 **Measuring the Resin Concentration of Solvent**

As more parts are cleaned, the solvent gradually becomes more concentrated with liquid resin, reducing the effectiveness of the Form Wash. Replace solvent when the wash is no longer effective and when parts have tacky surfaces after washing.



TIP

To significantly prolong the lifetime of the solvent before replacement, consider implementing a preliminary rinse with a small volume of solvent before inserting printed parts into the Form Wash.

Use a calibrated hydrometer to check the solvent's resin concentration between cleaning cycles and help determine when to replace the solvent. The included hydrometer is suitable for measuring the resin concentration in IPA (or another solvent with an equivalent specific gravity). Other solvents will require a hydrometer that can measure the correct specific gravity range. For example, TPM requires a hydrometer that can measure a specific gravity of 0.9–1.2, and a specific gravity greater than 1.0 indicates that the TPM will not be fully effective as a final wash. For more information about calibrating a hydrometer, see **4.3.4 Calibrate the Hydrometer (IPA Only)**. For additional recommendations for specific solvents, consult support.formlabs.com.

To check whether the solvent is suitable for cleaning parts:

1. Use the knob to select **Sleep** to lower the mount and close the lid of the Form Wash.
2. Open the outer lid.
3. Float the previously calibrated hydrometer in the wash bucket. Note the alignment of the O-ring relative to the float's wings.

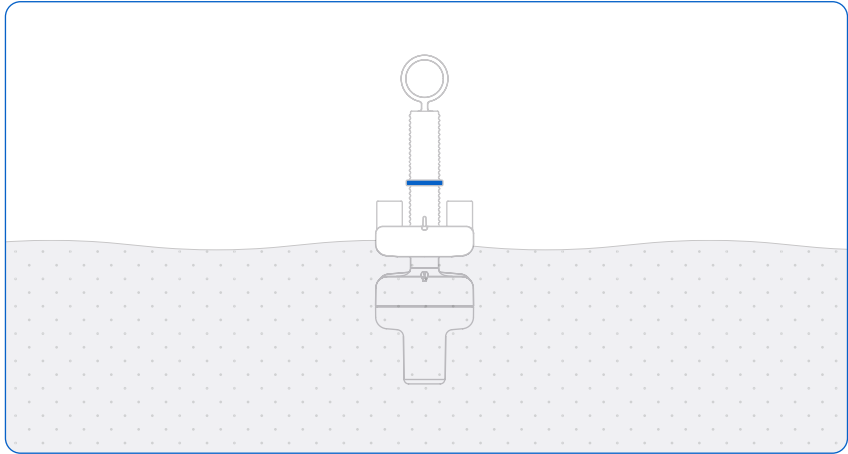

When calibrated properly, the O-ring should be set to align with the short wings in fresh solvent. As the solvent's resin concentration increases, the weight will float higher, and the stem and O-ring will rise.

For a smooth, dry surface finish, replace solvent when the O-ring rises above the float's tall wings.

5.4.3 **Powering Off the Form Wash**

Turn off the Form Wash completely when moving or storing the device and to conserve power. To turn off the Form Wash completely, disconnect the power cord from the power source. Ensure either the wall outlet or power supply is easily accessible.

The Form Wash display will automatically power off after a period of inactivity.

5.4.4 **Updating the Firmware**

The Form Wash includes a USB port for the possibility of future firmware updates. See **6.5.1 *Updating the Form Wash Firmware.***

5.4.5 **Accessing the Serial Name**

The serial name is on the back panel of the machine in the format "AdjectiveAnimal." The serial name is also available on the display. To access the serial name or firmware version on the display:

1. Disconnect the power cable.
2. Reconnect the power cable.
3. When the display shows **Formlabs**, press and hold the knob immediately. The display shows the serial name (preceded by **Wash-**) and firmware version.

5.5 Emergency and Exceptional Situations

Formlabs has made every effort to provide updated safety data sheets (SDS) for every resin product, in accordance with the latest government guidelines. Always consult the SDS as the primary source of information to understand safety and handling of Formlabs materials.



In an emergency involving resin, always refer to the safety data sheet and/or seek help from a medical professional.

When handling solvents, always consult the safety data sheet (SDS) from the solvent supplier as the primary source of information. Handle solvents with gloves in a well-ventilated area. Keep flammable solvents away from heat, sparks, and open flame. Some solvents evaporate rapidly, so keep bottles closed whenever possible.

Promptly clean and inspect the Form Wash if any liquid resin spills on the display or knob to minimize any cosmetic or functional damage to the device. If you have experienced an accidental resin spill, document the problem with photos and clean the unit as best as possible. Contact Formlabs or a certified service provider as soon as possible.

6. Maintenance



- Formlabs provides instructions to advise skilled and non-skilled persons in installing, operating, and maintaining the Form Wash. The Form Wash shall only be maintained by a qualified and trained person.
- Do not open the Form Wash and/or investigate internal components unless under the guidance of Formlabs or an authorized reseller. Contact Formlabs or an authorized reseller for any additional guidance.
- Unauthorized disassembly or repair procedures may damage the Form Wash and void the warranty.
- Wear personal protective equipment when performing maintenance tasks. Use tools only as described.
- Disconnect the power cable before maintenance.

Isopropyl alcohol (IPA) is suitable to clean most surfaces, including cured and uncured resin. When wiping the outer surfaces of the Form Wash, use a non-abrasive cloth. Other materials may scratch the unit.

Formlabs products perform best when they are well-maintained and properly cared for. As more parts are cleaned in the Form Wash, the solvent gradually becomes more concentrated with liquid resin, reducing the effectiveness of the Form Wash. As solvent evaporates, add fresh solvent to keep the fill level between the minimum and maximum lines. Use a calibrated hydrometer to check the solvent's resin concentration between cleaning cycles, and replace solvent as needed for the cleanest parts.

6.1 Inspecting the Product

6.1.1 Before Each Wash Cycle

INSPECT	REFER TO	SECTION
Installation environment	Operational Environment	5.1
Solvent volume	Fill Wash Bucket with Solvent	4.3.2
Parts to be washed	Considerations for Specific Geometries	5.3

6.1.2 Monthly

INSPECT	REFER TO	SECTION
Resin concentration of solvent	Measuring the Resin Concentration of Solvent	5.4.2

6.1.3 Every 3 Months

INSPECT	REFER TO	SECTION
Clean the wash bucket	Replacing Solvent	6.5.2

6.2 Inspection Tasks Between Wash Cycles

6.2.1 Maintaining Solvent Volume

The level of solvent in the Form Wash will decrease over time due to use and evaporation. Before starting a wash cycle, ensure that the solvent level in the wash bucket is between the minimum and maximum fill lines. If the solvent level is below the minimum fill line, parts washed on the build platform may not be fully immersed in the solvent during the wash. To add solvent to the Form Wash, follow the instructions in **4.3.2 Fill Wash Bucket with Solvent**.



To decrease the rate of solvent evaporation, especially for volatile solvents, lower the basket and keep the outer lid closed when the Form Wash is not in use.

6.2.2 Inspecting Parts Before Washing

Inspect all parts after printing to determine the best washing process. Very small parts may pass through the wash basket and impede the impeller. Larger prints may not fit in the Form Wash in certain orientations or may cause the Form Wash to overflow. See **5.3 Considerations for Specific Geometries** for further information.

6.3 Monthly Inspection and Maintenance Tasks

6.3.1 Measuring Resin Concentration

Measure the resin concentration of the solvent on a regular basis using a calibrated hydrometer. If you are using IPA as your wash solvent (or another solvent with an equivalent specific gravity), use the hydrometer included with the Form Wash. For instructions on how to calibrate and use a hydrometer, see **5.4.2 Measuring the Resin Concentration of Solvent**.

You can also gauge the level of resin concentration in the solvent by whether or not parts are fully clean after washing. Contaminated solvent will not be as effective as fresh solvent, but will not damage parts and can still be used as part of a multi-step washing process. For more information, see **5.4.1 Extending Solvent Lifetime**.

6.4 Periodic Inspection and Maintenance Tasks

6.4.1 Cleaning the Wash Bucket

Over time, dissolved resin will accumulate on the walls of the wash bucket. Periodically, while replacing the solvent, clean out the wash bucket to remove these resin deposits. Rinse the wash bucket with fresh solvent and wipe with a paper towel. For additional information on replacing the solvent in the Form Wash, see **6.5.2 Replacing Solvent**.

6.5 Planned Maintenance Procedures

Maintenance tasks shall be done according to the following plan:

TASK	FREQUENCY	SECTION
Update the firmware	When indicated by Formlabs	6.5.1
Replace solvent	When indicated by a calibrated hydrometer	6.5.2
Dispose of used solvent	After replacing solvent	6.5.3

6.5.1 Updating the Form Wash Firmware

Formlabs regularly releases updated firmware to fix bugs and improve functionality. Review the PreForm and firmware release notes to learn more about the improvements that come with each version's release.

To update the firmware:

1. Connect the Form Wash with a USB cable to a computer running the latest version of PreForm.
2. Locate and run the Form Wash/Cure Updater tool in the PreForm installation folder to check for firmware updates and to update the firmware.
3. When the updater tool detects the unit, select **Update Firmware**.
4. The tool uploads the new firmware and restarts the unit to complete the update. The update should take approximately 20 seconds.



NOTICE

Do not disconnect the USB or power cables during the update.

5. **Firmware Up To Date** appears next to the connected unit in the main updater window. Select **Done** once the update is complete.
6. Repeat steps 1–5 to update firmware on additional Form Wash units.
7. Select **Quit** to close the updater.

6.5.2 Replacing Solvent

Use the following supplies to replace the solvent in the Form Wash:

- Siphon pump, included with the Form Wash
- Empty container, suitable for storing up to 8.6 L of solvent
- 8.6 L of fresh solvent

Follow these steps to transfer solvent from the Form Wash into a chemical resistant container that is safely designated for highly-resin-concentrated solvent and to refill the wash bucket with fresh solvent:

1. Remove the wash bucket and inner lid

Start with the outer lid open, the platform mount raised, and the basket removed. Lift the wash bucket forward and upward to remove it from the base. Set the wash bucket on a clean, stable surface, then lift to remove the inner lid.

2. Use the siphon pump to remove solvent from the wash bucket

The siphon pump uses gravity to transfer liquid between containers. For optimal flow, elevate the source above the receiving container.

Insert the rigid tube into the used solvent and the flexible tube into your used solvent storage vessel. To initiate flow, squeeze the siphon pump handle several times, then hold. Gradually release the handle when liquid begins flowing automatically.



NOTICE

Watch the siphon pump after initiating flow. The flow will continue automatically as long as the source container's fill level remains elevated above the receiving container.

3. **Clean the wash bucket (optional)**

For the cleanest wash, rinse the wash bucket with solvent and wipe with a paper towel.



Use separate wash buckets to preserve part color, quality, and performance. Maintain separate equipment to meet biocompatibility requirements.

4. **Refill with fresh solvent**

Use the siphon pump or pour from a container of fresh solvent to refill the wash bucket between the minimum and maximum fill lines.

5. **Install the inner lid**

Align the front edge of the inner lid with the wash bucket's edge, then lower the lid directly onto the top of the bucket.

6.5.3

Disposing of Used Solvent

Formlabs encourages safe and responsible management of materials and equipment, including solvent. Always consult the safety data sheet (SDS) from your solvent supplier as the primary source of information for storage and handling. Research local laws and options for recycling and disposing of solvent that is used and combined with photopolymer resin.



Do not pour liquid resin down the drain. Follow instructions in the SDS.

7. Troubleshooting and Repair

For detailed guidance and visual assistance, search on support.formlabs.com.

7.1 Restarting with a Power Cycle

If the display freezes during or after the firmware update, power cycle the Form Wash unit:

1. Unplug the unit.
2. Wait at least 10 seconds to ensure a complete power cycle.
3. Reconnect the power cable to restart the unit.

7.2 Troubleshooting

In the case of an error or abnormal activity with the Form Wash, reference the following errors, causes, and proposed solutions. Complete the initial troubleshooting steps and carefully document all results. Contact Formlabs or an authorized reseller for additional assistance.

ERROR	CAUSE	SOLUTION
Outer lid does not close fully	Outer lid hinge is broken	Contact Formlabs or an authorized reseller for instructions to replace the outer lid hinge.
Unusual noises	Misaligned impeller Debris or obstructions in the wash bucket	Check for loose cured material or debris in the bottom of the wash bucket. Check that the impeller rotates properly. If not, contact Formlabs or an authorized reseller for instructions to reverse the magnets.
Motor Jammed error message	Inner lid resting on hinge plate	Disconnect power. Manually lift the tower to its maximum height. Remove the wash bucket. Press down on the edges of the inner lid, so that the lid is flush with the bucket. Reinsert the wash bucket. Ensure the inner lid stays flush with the bucket.
The display does not turn off or sleep	Firmware bug	Disconnect and reconnect the power. Update the firmware. See 6.5.1 Updating the Form Wash Firmware.
The display does not turn on	Power failure or a faulty electrical connection	Check that the power supply indicator light is illuminated. Try another outlet. Disconnect and reconnect the power.
Washed parts have tacky or sticky surfaces.	Resin concentration in solvent is too high	Replace the solvent in the Form Wash. See 6.5.2 Replacing Solvent.

7.3 Disassembly and Repair



All steps that involve opening the Form Wash and/or investigating internal components should be done by skilled persons under the guidance of Formlabs or a certified service provider.

Contact Formlabs or a certified service provider to receive repair instructions and authorization. The following tools, equipment, and materials are needed for reparation tasks:

TASK	REQUIRED SUPPLIES	CAUSE
Replacing the Display Assembly	2.5 mm hex wrench, replacement part(s)	The Form Wash display or knob has stopped functioning.
Reseating the Magnetic Clutch	2.0 mm hex wrench, 2.5 mm hex wrench, calipers	Unusual noises during wash cycle Erratic impeller movement
Replacing the Outer Lid Hinge	2.0 mm hex wrench, replacement part(s)	Outer lid does not close fully or move smoothly
Reseating the Ribbon Cable	2.5 mm hex wrench	The Form Wash display or knob has stopped functioning.

8. Disposal

8.1 Guidance for Recycling and Disposal

8.1.1 Disposal of electronic components



The symbol on the product, accessories, or packaging indicates that this device must not be treated as nor disposed of with household waste. When you decide to dispose of this product, do so in accordance with local environmental laws and guidelines. Dispose of the device via a collection point for the recycling of waste electrical and electronic equipment. By disposing of the device in the proper manner, you help to avoid possible hazards for the environment and public health that could otherwise be caused by improper treatment of waste equipment. The recycling of materials contributes to the conservation of natural resources. Therefore do not dispose of your old electrical and electronic equipment with the unsorted municipal waste.

8.1.2 Disposal of packaging waste

Keep the packaging for transporting your Form Wash. Form Wash packaging materials are designed to be kept and reused for transportation or shipping.

The packaging is made of cardboard and plastic-based materials. Dispose of packaging through your local waste and recycling facilities. By disposing of the packaging waste in the proper manner, you help to avoid possible hazards for the environment and public health.

8.1.3 Disposal of solvent and resin

For printing operations without access to a solvent recycling system, note that safe and appropriate disposal methods of used solvent will vary by location.



NOTICE

Do not pour liquid or partially cured resin into drains or dispose of it with household waste. Do not pour solvent that contains dissolved resin into drains or dispose of it with household waste.

Consult the safety data sheet (SDS) from the solvent supplier as the primary source of information.

Research your local government's approved methods of disposal. This will most likely involve hiring a waste disposal service or, for smaller amounts, checking with your city's disposal service to see if they have any suggestions for removal.

Inform your waste disposal service that your bottle contains a particular solvent with small amounts of methacrylated monomers and oligomers (unpolymerized plastic resin) and trace amounts of photoinitiator. Have a copy of the resin's SDS on hand in case the attendant needs more information.

9. Index

B

- basket** 11, 12, 16, 18, 20, 21, 22, 27, 28, 34
 - basket mount 12, 16, 18, 20, 34
- build platform** 11, 13, 18, 20, 21, 22, 23, 27, 34

C

- clean** 11, 15, 20, 21, 22, 23, 25, 26, 27, 28
 - cleaning 11, 13, 22, 23, 24, 26
- comply** 10, 14, 23
 - compliance 8, 10

D

- display** 12, 20, 21, 24, 25, 30, 31, 34
- disposal** 14, 32

F

- firmware** 17, 24, 27, 28, 30

H

- hydrometer** 11, 16, 18, 23, 24, 26, 27, 34

I

- impeller** 11, 12, 27, 30, 31, 34
- install** 16, 20
 - installation 8, 16, 28
- isopropyl alcohol** 11, 15, 16
 - IPA 11, 15, 16, 18, 23, 26, 27

K

- knob** 12, 20, 21, 24, 25, 31, 34

L

- lid** 11, 15, 17, 18, 21, 22, 24, 27, 28, 29, 30, 31, 34
 - inner lid 18, 21, 22, 28, 29, 30
 - outer lid 18, 21, 22, 28, 29, 30

M

- maintenance** 8, 26
- motor** 34

O

- operation** 8, 13

P

- package**
 - packaging 16, 18, 19, 32
- platform mount** 20, 21, 28, 34
- power** 11, 12, 13, 16, 17, 19, 24, 26, 28, 30, 34

R

- resin** 10, 11, 13, 14, 15, 18, 21, 22, 23, 24, 25, 26, 27, 28, 29, 32, 34

S

- safety** 7, 8, 10, 13, 14, 21, 22, 25, 29, 32
- Safety Data Sheet** 14
 - SDS 14, 15, 21, 25, 29, 32
- shipping** 18, 19, 32
- siphon** 15, 16, 17, 28, 29, 34
- solvent** 11, 14, 15, 16, 17, 18, 20, 21, 22, 23, 24, 25, 26, 27, 28, 29, 30, 32, 34
- specifications** 10

T

- technical data** 10
- temperature** 20, 34
- tool storage** 18, 34
- transport** 18
 - transporting 15, 32
- tripropylene glycol monomethyl ether**
 - TPM 21, 23

U

- unboxing** 16
- USB** 17, 24, 28, 34

W

- warranty** 8, 9, 10, 16, 18, 19, 26
- wash bucket** 11, 15, 16, 17, 18, 20, 21, 22, 23, 24, 26, 27, 28, 29, 30, 34

10. Glossary

TERM	MEANING
Basket	Holds parts to wash without the build platform.
Basket mount	A single hook secures the basket to raise and lower.
Display	The display shows status, time, temperature, and options for configuring the Form Wash.
Display ribbon cable	A flat, flexible cable connects the display assembly to the motherboard.
Hydrometer	Use a hydrometer to measure the solvent's resin concentration (based on previous calibration in fresh solvent).
Impeller	An impeller at the bottom of the wash bucket couples to the Form Wash using magnets and agitates the solvent during the wash cycle.
Impeller motor	The impeller motor, located in the base of the Form Wash, uses magnets to spin the impeller in the wash bucket.
Inner lid	A hinged, secondary lid opens and closes to contain solvent while allowing parts to be lowered or raised from the bucket.
Knob	The knob is the primary interface device for the Form Wash. Turn the knob to navigate the display menu. Press the knob to select a feature or setting.
Lid hinges	The inner and outer lids are hinged, allowing them to open and close automatically as the platform mount and basket mount raise and lower.
Magnetic clutch	The magnetic clutch couples the impeller to the Form Wash without a mechanical connection.
Motherboard	The motherboard is the main circuitry through which all systems in the Form Wash communicate.
Outer lid	Limits solvent evaporation. Keep the lid closed when not in use.
Platform mount	Holds the build platform when washing parts on the platform.
Power supply	Provides power to the Form Wash. Specifications: 24 V, 2 A
Siphon pump	The Form Wash includes a manual siphon pump, used to transfer solvent between the wash bucket and a solvent storage container.
Solvent	Not included. Dissolves liquid resin from printed parts' surfaces.
Tool storage	The Form Wash includes small tool storage cabinets on each side of the unit to store part washing accessories.
USB port	The Form Wash can connect to a computer via USB. The port is connected to the motherboard and can be accessed from the back of the machine.
Wash bucket	A removable container in the Form Wash holds a maximum of 8.6 L of solvent. A rotating impeller at the bottom circulates the solvent.
Z-tower motor	The Form Wash Z-tower motor assembly raises and lowers the platform mount and basket mount.

